

CIRCULATION UNIT

MIXING FUNCTION, SERIES GRxX00



PRODUCT DESCRIPTION

The mixing groups are used for the temperature control, mixing function, in heating systems. This means that the heating water prepared in the heating source is mixed down to the desired set temperature, which is then delivered to the heating receiver, e.g. underfloor heating. The units GRxx00 are equipped with rotating mixing valves and actuators. The temperature control, mixing function, is performed based on a signal from an external controller. The mixed temperature is then a result of the controller parameters setting. For example, if the external controller is a weather compensated controller, the mixed temperature will be calculated based on the controller's heating curve settings. The groups are used in systems with controllers, and it depends on the controller type and functions which level of comfort that will be delivered.

Products are equipped with two shut-off valves with colour coded thermometers, a check valve placed on the return line from the heating circuit and an insulation shell. All circulation units are equipped with 3-way rotary mixing valves with progressive characteristic for smooth and precise temperature control.

When designing the circulation unit product line ESBE focused on performance, design, user friendly usage and environment. This applies to everything from manufacturing, materials to packaging.

KEY BENEFITS

- High class insulation of hydronic parts
- Compact design
- Pre tested and ready to use
- Ready for 180mm pumps - applies to GRF100
- Adjustable insulation shell - applies to GRF100
- Symmetric design for left/right pump placement - applies to GRA200 and GRF100
- Designed to last and perform
- High-end product finish

VERSIONS

ESBE mixing function circulation units are available in three different version; standard design with and without pump, and a compact design for areas with limited space. The compact version can be delivered with and without insulation shell and actuator.

SERIES GRA200

The ESBE series GRA200 is a circulation unit equipped with a pump and a 3-way rotary mixing valve with progressive characteristic. The series comes in two sizes, DN25 and DN32 with the possibility of pump choice, Wilo or Grundfos.

The pumps can be set to constant speed, variable pressure or constant pressure. The Grundfos pumps come with AutoADAPT feature which adjust the available pump pressure and the flow to the current system requirements.

The circulation units comes with two different versions of actuator; GRA210 with assembled 3-point 230V AC actuator series ARA661, and GRA230 with assembled proportional 24V AC/DC actuator series ARA639. The Series GRA200 has an ESBE QuickFIT interface between actuator and valve that allows for assembly or disassembly of the actuator from the valve without any tools.

The compact design of the unit has been thought through and focus put on components such as pump resulted in high performance of the circulation unit.

SERIES GRA300

The ESBE series GRA300 is a compact but powerful circulation unit design for applications where space matters, however there is no room for compromises. The GRA300 is a DN20 circulation unit with performance equals the corresponding DN25 groups. This could be possible by adjusting the pump curves and consider the pressure losses in the group. By putting focus on performance, we achieved the smallest circulation unit with unique pump curves which are covering low and high demands.

The GRA310 is equipped with a Wilo pump which can be set to variable or constant pressure, and iPWM1/2. It is also equipped with 3-way rotary mixing valve with progressive characteristic and an assembled 3-point 230V AC actuator series ARA661. Series GRA310 also has an ESBE QuickFIT interface between actuator and valve that allows for assembly or disassembly of the actuator from the valve without any tools.

The GRA390 is equipped with a Wilo PARA 15/6 which can be set to constant speed, variable pressure or constant pressure. It has a 3-way rotary mixing valve with progressive characteristic and come with a knob for manual adjustments, but can be equipped with your preferred actuator or controller. The GRA390 is the only version that isn't equipped with insulation shell.

SERIES GRF100

The ESBE series GRF100 is a circulation unit with mixing function, available in size DN25, designed to be used with almost any 180mm pump available on the market. The circulation unit is equipped with an insulation shell which can be adjusted according to pump design, even if the pump is delivered with its own insulation.

ESBE have put a lot of effort to make the adjustment process easy and clear, and to make the result of product adjustment like factory assembly.

The series GRF100 are equipped with a 3-way rotary mixing valve with progressive characteristic. It comes in two versions; GRF111 which can be equipped with your preferred actuator or

CIRCULATION UNIT

MIXING FUNCTION, SERIES GRxX00

controller, and GRF121 which comes with assembled 3-point 230V AC actuator series ARA661.

SERVICE AND MAINTENANCE

The circulation unit does not require any specific maintenance under normal conditions.

RELATED ACCESSORIES

ESBE Actuator

When an actuator is preferred ESBE recommend two different variants; ARA661 3-point 230V AC or a ARA639 prop. 24V AC/DC. Equipped with an actuator the units adjust the heating water temperature to required temperature for the heating circuit based on a signal from an external controller. The mixed temperature is a result of the controller parameters setting. For example, if the external controller is a weather/ outdoor temperature compensated controller, the mixed temperature will be calculated based on the controller's heating curve settings. See separate data sheet for further detailed information.

Art. No.

12520100 _____ ARA639 Prop./Multi 24VAC 15-120s 6Nm
12101300 _____ ARA661 3-point SPDT 230VAC 120s 6Nm

ESBE Controller

When a controller is preferred, ESBE recommend four different variants: CRA211, CRB211, CRC211 and CRD221.

Equipped with a controller the units itself adjust the heating water temperature to the required temperature for the heating circuit based on the heating curve or measured indoor/outdoor temperature, depending on the choice of ESBE controller. See separate data sheet for further detailed information.

Art. No.

12721100 _____ CRA211 Const. temperature Controller 5-95°C
12663100 _____ CRB211 Indoor Controller
12821100 _____ CRC211 Outdoor Controller
12684200 _____ CRD221 Indoor/Outdoor Controller

ESBE Manifold

Manifolds for Series GRF100 and GRA200. See separate data sheet for further detailed information.

Manifolds for 1, 2, or 3 circulation units with integrated hydraulic separation.

Art. No.

66001100 _____ GMA411- for 1 unit
66001600 _____ GMA521 - for 2 units
66001700 _____ GMA531 - for 3 units

Manifold for 2, 3, 4 or 5 circulation units without integrated hydraulic separation function.

Art. No.

66001200 _____ GMA421- for 2 units
66001300 _____ GMA431 - for 3 units
66001400 _____ GMA441 - for 4 units
66001500 _____ GMA451 - for 5 units

Manifold for Series GRA300 without integrated hydraulic separation function. See separate data sheet for further detailed information.

Art. No.

66000500 _____ GMA321- for 2 units
66000600 _____ GMA331 - for 3 units

ESBE Manifold Box

Manifold Box for Series GRA300 with option of hydraulic separation easily set with a screw. See separate data sheet for further detailed information.

Art. No.

66000700 _____ GMB631 for 2 or 3 units

CIRCULATION UNIT

MIXING FUNCTION, SERIES GRxX00

PRODUCT ASSORTMENT

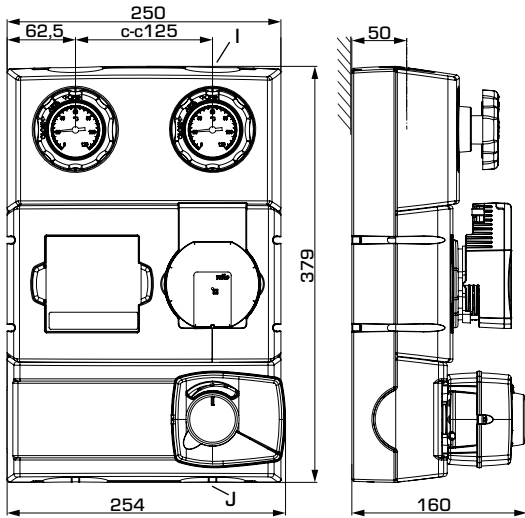

GRA211, GRA231

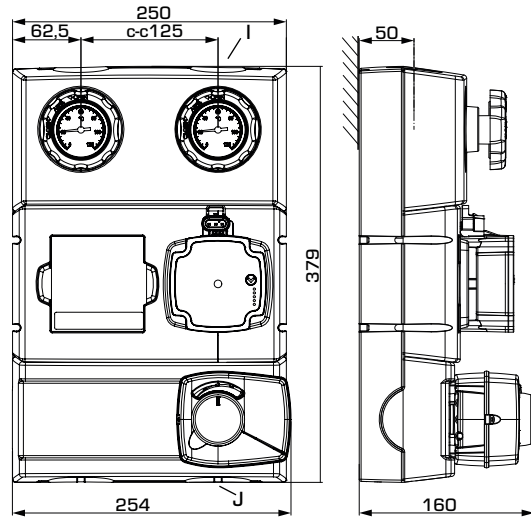

GRA212, GRA232

SERIES GRA210

Art. No.	Reference	DN	Pump	Connections		Weight [kg]	Note	Replaces
				I	J			
61042100	GRA211	25	Wilo PARA 25/6	G 1"	G 1½"	5,8	230V, 3 point control signal	61040100
61042200		32	Wilo PARA 25/8	G 1¼"	G 1½"	6,2		61040400
61042300	GRA212	25	Grundfos UPM3 AUTO 25-50	G 1"	G 1½"	5,9		61040500
61042400		32	Grundfos UPM3 AUTO25-70	G 1¼"	G 1½"	6,1		61040600

SERIES GRA230

Art. No.	Reference	DN	Pump	Connections		Weight [kg]	Note	Replaces
				I	J			
61042500	GRA231	25	Wilo PARA 25/6	G 1"	G 1½"	5,8	24V, Proportional control signal	61043200
61042600		32	Wilo PARA 25/8	G 1¼"	G 1½"	6,2		61043300
61042700	GRA232	25	Grundfos UPM3 AUTO 25-50	G 1"	G 1½"	5,9		61043400
61042800		32	Grundfos UPM3 AUTO 25-70	G 1¼"	G 1½"	6,1		61043500

CIRCULATION UNIT

MIXING FUNCTION,

SERIES GRxX00

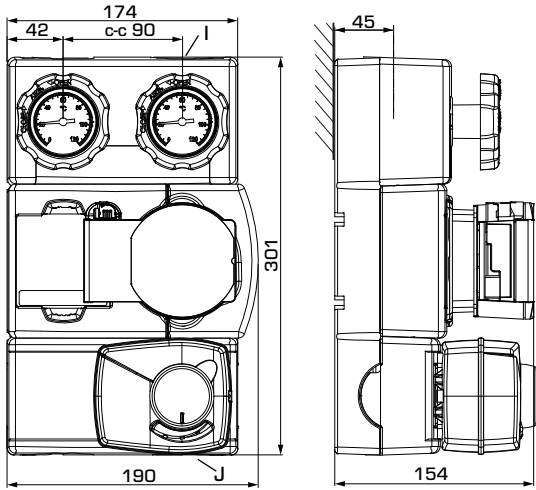

GRA311

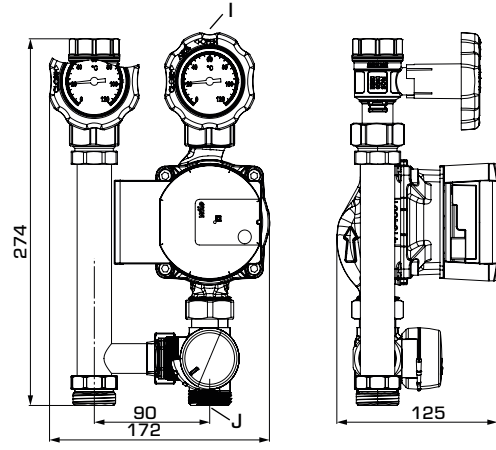

GRA394

SERIES GRA300

Art. No.	Reference	DN	Pump	Connections		Weight [kg]	Note
				I	J		
61043600	GRA311	20	Wilo PARA STG 15/8	G 3/4"	G 1"	4,5	Replaces 61043100 without actuator and insulation shell
61045800	GRA394		Wilo PARA 15/6				

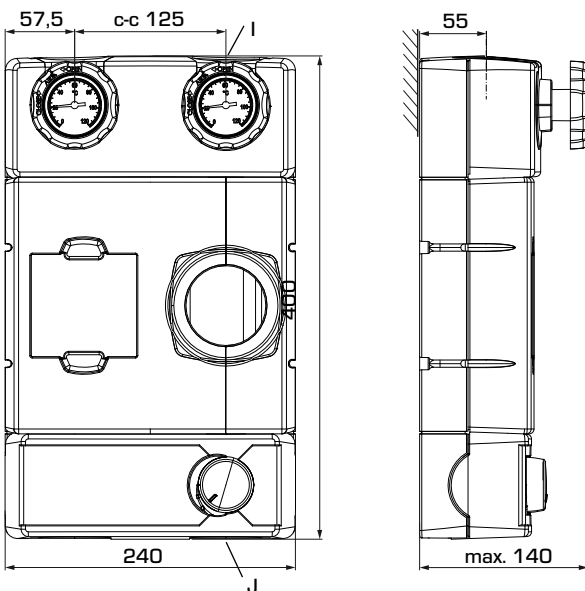

GRF111

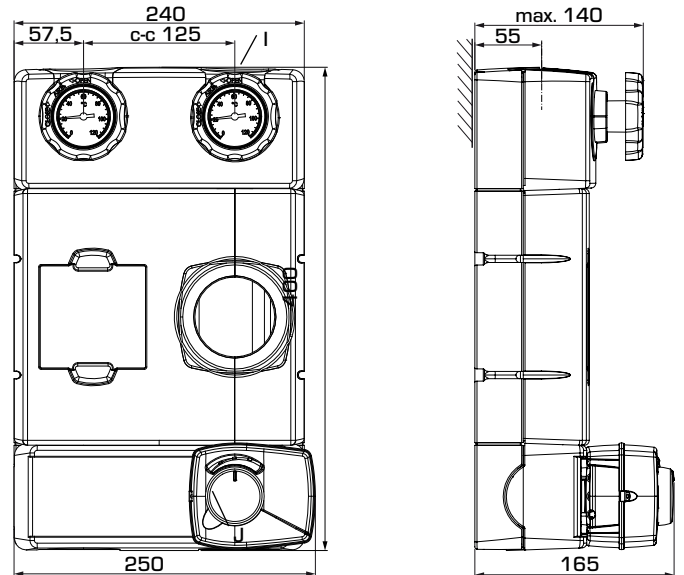

GRF121

SERIES GRF100

Art. No.	Reference	DN	Connections		Weight [kg]	Note
			I	J		
61240100	GRF111	25	G 1"	G 1 1/2"	3,4	
61241100	GRF121	25	G 1"	G 1 1/2"	3,8	230V, 3 point control signal

CIRCULATION UNIT

MIXING FUNCTION, SERIES GRxX00

TECHNICAL DATA

 Visit esbe.eu for further detailed information.

The Circulation unit, in general

Pressure class: _____ PN 10
 Working pressure: _____ 1,0 MPa (10 bar)
 Connections, _____ Internal thread (G), ISO 228/1
 _____ External thread (G), ISO 228/1
 Insulation: _____ EPP λ 0,036 W/mK

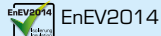

Media: _____ Heating water (in accordance with VDI2035)
 _____ Water / Glycol mixtures, max. 50%.
 Water / glycol mixtures are affecting the pump performance. In case of Applications where water / glycol mixtures are used, pump performance should be considered.

Series GRA211



Media temperature: _____ max. +100°C
 _____ min. +5°C
 Ambient temperature: _____ max. +55°C
 _____ min. 0°C
 Pump type, DN25: _____ Wilo PARA 25-130/6-43/SC
 DN32: _____ Wilo PARA 25-130/8-75/SC
 Power supply: _____ 230 ± 10% V AC, 50/60 Hz
 Power consumption - Wilo PARA 25/6: _____ 3-43 W
 - Wilo PARA 25/8 _____ 10-75 W
 Enclosure rating: _____ IP X4D
 Insulation class: _____ F
 EEI (Energy Efficiency Index) - Wilo PARA 25/6: _____ <0,20
 - Wilo PARA 25/8: _____ <0,21
 Valve type: _____ Mixing valve VRG432
 Max. differential pressure drop: _____ 100kPa (1 bar)
 Close off pressure: _____ 200 kPa (2 bar)
 Leakrate in % of flow*: _____ < 0,05%
 * Differential pressure 100kPa (1 bar)

Actuator type: _____ ARA661
 Control signal: _____ 3-point
 Power supply: _____ 230 ± 10% V AC, 50 Hz
 Power consumption: _____ 5 VA
 Running time 90°: _____ 120s
 Enclosure rating: _____ IP41
 Protection class: _____ II

Material, in contact with water

Components: _____ Brass, Cast iron, Steel
 Sealing material: _____ PTFE, Aramid fibre, EPDM

Conformities and certificates

 LVD 2014/35/EU
 EMC 2014/30/EU
 RoHS3 2015/863/EU
 ErP 2009/125/EU
 SI 2016 No. 1101
 SI 2016 No. 1091
 SI 2012 No. 3032
 SI 2010 No. 2617
 PED 2014/68/EU, article 4.3 / SI 2016 No. 1105 (UK)

Series GRA212



Media temperature: _____ max. +110°C
 _____ min. +5°C
 Ambient temperature: _____ max. +55°C
 _____ min. 0°C
 Pump type, DN25: _____ Grundfos UPM3 AUTO 25-50 130
 DN32: _____ Grundfos UPM3 AUTO 25-70 130
 Power supply: _____ 230 ± 10% V AC, 50/60 Hz
 Power consumption - Grundfos UPM3 AUTO 25-50: _____ 4-33 W
 - Grundfos UPM3 AUTO 25-70 _____ 2-52 W
 Enclosure rating: _____ IP 44
 Insulation class: _____ N/A
 EEI (Energy Efficiency Index): _____ <0,20
 Valve type: _____ Mixing valve VRG432
 Max. differential pressure drop: _____ 100kPa (1 bar)
 Close off pressure: _____ 200 kPa (2 bar)
 Leakrate in % of flow*: _____ < 0,05%
 * Differential pressure 100kPa (1 bar)

Actuator type: _____ ARA661
 Control signal: _____ 3-point
 Power supply: _____ 230 ± 10% V AC, 50 Hz
 Power consumption: _____ 5 VA
 Running time 90°: _____ 120s
 Enclosure rating: _____ IP41
 Protection class: _____ II

Material, in contact with water

Components of: _____ Brass, Cast iron, Steel
 Sealing material of: _____ PTFE, Aramid fibre, EPDM

Conformities and certificates

 LVD 2014/35/EU
 EMC 2014/30/EU
 RoHS3 2015/863/EU
 ErP 2009/125/EU
 SI 2016 No. 1101
 SI 2016 No. 1091
 SI 2012 No. 3032
 SI 2010 No. 2617
 PED 2014/68/EU, article 4.3 / SI 2016 No. 1105 (UK)

CIRCULATION UNIT

MIXING FUNCTION, SERIES GRxX00

TECHNICAL DATA

 Visit esbe.eu for further detailed information.

Series GRA231

Media temperature: _____ max. +100°C
 _____ min. +5°C
 Ambient temperature: _____ max. +55°C
 _____ min. 0°C
 Pump type, DN25: _____ Wilo PARA 25-130/6-43/SC
 DN32: _____ Wilo PARA 25-130/8-75/SC
 Power supply: _____ 230 ± 10% V AC, 50/60 Hz
 Power consumption - Wilo PARA 25/6: _____ 3-43 W
 - Wilo PARA 25/8 _____ 10-75 W
 Enclosure rating: _____ IP X4D
 Insulation class: _____ F
 EEI (Energy Efficiency Index) - Wilo PARA 25/6: _____ <0,20
 - Wilo PARA 25/8: _____ <0,21
 Valve type: _____ Mixing valve VRG432
 Max. differential pressure drop: _____ 100kPa (1 bar)
 Close off pressure: _____ 200 kPa (2 bar)
 Leakrate in % of flow*: _____ < 0,05%
 * Differential pressure 100kPa (1 bar)

Actuator type: _____ ARA639
 Control signal: _____ proportional
 Feedback signal: _____ 2-10 V
 Power supply: _____ 24 ± 10% V AC/DC, 50/60 Hz
 Power consumption - Operation, AC: _____ 5 W
 DC: _____ 2,5 W
 Power consumption - Dimensioning, AC: _____ 11 VA
 DC: _____ 6 VA
 Running time 90°: _____ 15/30/60/120s
 Enclosure rating: _____ IP41
 Protection class: _____ II

Material, in contact with water

Components: _____ Brass, Cast iron, Steel
 Sealing material: _____ PTFE, Aramid fibre, EPDM

Conformities and certificates

 LVD 2014/35/EU SI 2016 Nr. 1101
 EMC 2014/30/EU SI 2016 Nr. 1091
 RoHS3 2015/863/EU SI 2012 Nr. 3032
 ErP 2009/125/EU SI 2010 Nr. 2617

PED 2014/68/EU, artikel 4.3 / SI 2016 Nr. 1105 (UK)

Series GRA232

Media temperature: _____ max. +110°C
 _____ min. +5°C
 Ambient temperature: _____ max. +55°C
 _____ min. 0°C
 Pump type, DN25: _____ Grundfos UPM3 AUTO 25-50 130
 DN32: _____ Grundfos UPM3 AUTO 25-70 130
 Power supply: _____ 230 ± 10% V AC, 50/60 Hz
 Power consumption - Grundfos UPM3 AUTO 25-50: _____ 4-33 W
 - Grundfos UPM3 AUTO 25-70 _____ 2-52 W
 Enclosure rating: _____ IP 44
 Insulation class: _____ N/A
 EEI (Energy Efficiency Index): _____ <0,20
 Valve type: _____ Mixing valve VRG432
 Max. differential pressure drop: _____ 100kPa (1 bar)
 Close off pressure: _____ 200 kPa (2 bar)
 Leakrate in % of flow*: _____ < 0,05%
 * Differential pressure 100kPa (1 bar)

Actuator type: _____ ARA639
 Control signal: _____ proportional
 Feedback signal: _____ 2-10 V
 Power supply: _____ 24 ± 10% V AC/DC, 50/60 Hz
 Power consumption - Operation, AC: _____ 5 W
 DC: _____ 2,5 W
 Power consumption - Dimensioning, AC: _____ 11 VA
 DC: _____ 6 VA
 Running time 90°: _____ 15/30/60/120s
 Enclosure rating: _____ IP41
 Protection class: _____ II

Material, in contact with water

Components: _____ Brass, Cast iron, Steel
 Sealing material: _____ PTFE, Aramid fibre, EPDM

Conformities and certificates

 LVD 2014/35/EU SI 2016 Nr. 1101
 EMC 2014/30/EU SI 2016 Nr. 1091
 RoHS3 2015/863/EU SI 2012 Nr. 3032
 ErP 2009/125/EU SI 2010 Nr. 2617

PED 2014/68/EU, artikel 4.3 / SI 2016 Nr. 1105 (UK)

Series GRA300

Media temperature: _____ max. +100°C
 _____ min. +5°C
 Ambient temperature: _____ max. +55°C
 _____ min. 0°C
 Pump type, GRA311: _____ Wilo PARA STG 15-130/8-60/0
 GRA394: _____ Wilo PARA 25-130/6-43/SCU
 Power supply: _____ 230 ± 10% V AC, 50/60 Hz
 Power consumption: _____ 2-60 W
 Enclosure rating: _____ IP X4D
 Insulation class: _____ F
 EEI (Energy Efficiency Index): _____ <0,20
 Valve type: _____ Mixing valve VRG438
 Max. differential pressure drop: _____ 100kPa (1 bar)
 Close off pressure: _____ 200 kPa (2 bar)
 Leakrate in % of flow*: _____ < 0,05%
 * Differential pressure 100kPa (1 bar)

Actuator type: _____ ARA661
 Control signal: _____ 3-point
 Power supply: _____ 230 ± 10% V AC, 50 Hz
 Power consumption: _____ 5 VA
 Running time 90°: _____ 120s
 Enclosure rating: _____ IP41
 Protection class: _____ II

Material, in contact with water

Components: _____ Brass, Cast iron, Steel
 Sealing material: _____ PTFE, Aramid fibre, EPDM

Conformities and certificates

 LVD 2014/35/EU SI 2016 Nr. 1101
 EMC 2014/30/EU SI 2016 Nr. 1091
 RoHS3 2015/863/EU SI 2012 Nr. 3032
 ErP 2009/125/EU SI 2010 Nr. 2617

PED 2014/68/EU, artikel 4.3 / SI 2016 Nr. 1105 (UK)

CIRCULATION UNIT

MIXING FUNCTION, SERIES GRxX00

TECHNICAL DATA

 Visit esbe.eu for further detailed information.

Series GRF111

Media temperature: _____ max. +100°C*
 _____ min. +5°C*
 Ambient temperature: _____ max. +60°C*
 _____ min. 0°C*

* consider data for choosen pump

Pump type: _____ N/A
 Valve type: _____ Mixing valve VRG432
 Max. differential pressure drop: _____ 100kPa (1 bar)
 Close off pressure: _____ 200 kPa (2 bar)
 Leakrate in % of flow*: _____ < 0,05%
 * Differential pressure 100kPa (1 bar)

Material, in contact with water

Components: _____ Brass, Steel
 Sealing material: _____ PTFE, Aramid fibre, EPDM

Conformities and certificates

PED 2014/68/EU, article 4.3 / SI 2016 No. 1105 (UK)

Series GRF121

Media temperature: _____ max. +100°C*
 _____ min. +5°C*
 Ambient temperature: _____ max. +55°C*
 _____ min. 0°C*

* consider data for choosen pump

Pump type: _____ N/A
 Valve type: _____ Mixing valve VRG432
 Max. differential pressure drop: _____ 100kPa (1 bar)
 Close off pressure: _____ 200 kPa (2 bar)
 Leakrate in % of flow*: _____ < 0,05%
 * Differential pressure 100kPa (1 bar)

Actuator type: _____ ARA661
 Control signal: _____ 3-point
 Power supply: _____ 230 ± 10% V AC, 50 Hz
 Power consumption: _____ 5 VA
 Running time 90°: _____ 120s
 Enclosure rating: _____ IP41
 Protection class: _____ II

Material, in contact with water

Components: _____ Brass, Steel
 Sealing material: _____ PTFE, Aramid fibre, EPDM

Conformities and certificates

 LVD 2014/35/EU
 EMC 2014/30/EU
 RoHS3 2015/863/EU
 ErP 2009/125/EU

 SI 2016 No. 1101
 SI 2016 No. 1091
 SI 2012 No. 3032
 SI 2010 No. 2617

PED 2014/68/EU, article 4.3 / SI 2016 No. 1105 (UK)

VALVE CHARACTERISTICS, MIXING VALVE VRG430

Flow [%]

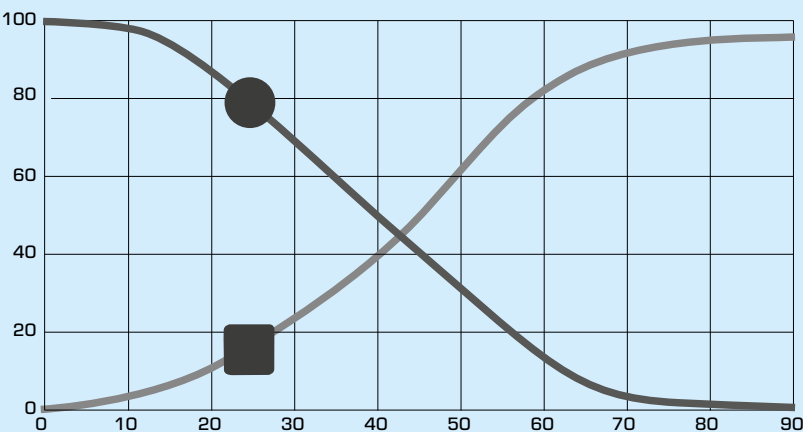

Opening angle [°]

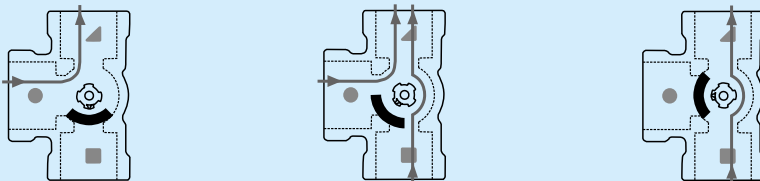

WIRING

Please see the Installation Instruction

CIRCULATION UNIT

MIXING FUNCTION, SERIES GRxX00

DIMENSIONING, PUMP CAPACITY DIAGRAM

Example: Start with the heat demand of the heating circuit (e.g. 25 kW) and move horizontally to the right in the diagram to the $\Delta t = 12^\circ\text{C}$ (temperature difference between flow and return of the heating circuit). Next go up and find the possible duty points.

Setting I gives duty point A with a residual head of 40 kPa for DN32. Setting II and III gives duty point B with a residual head of 59 kPa for DN32.

SERIES GRA211, GRA231 – Constant differential pressure, Wilo pump

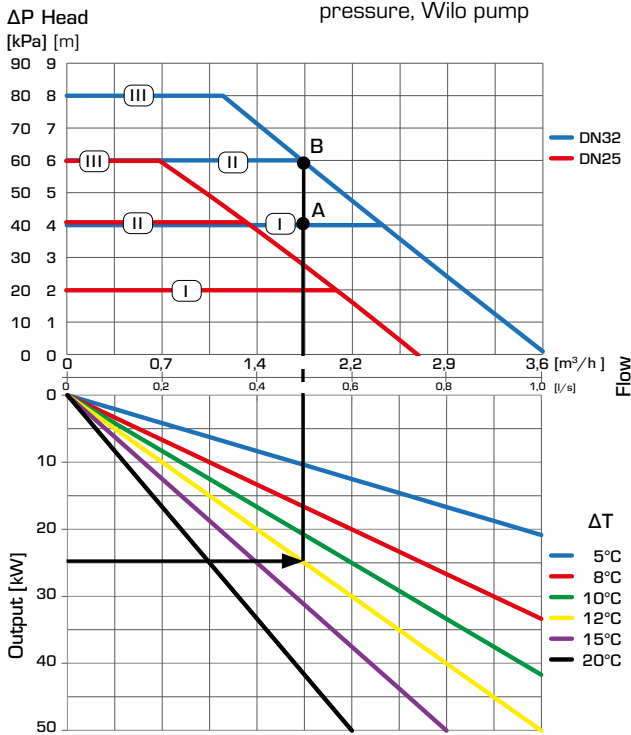

SERIES GRA211, GRA231 – Variable differential pressure, Wilo pump

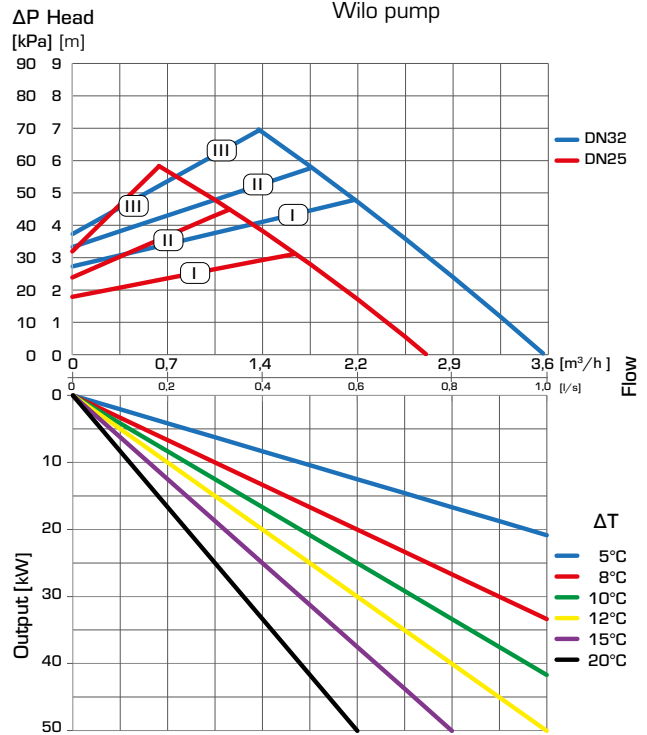

SERIES GRA211, GRA231 – Constant speed, Wilo pump

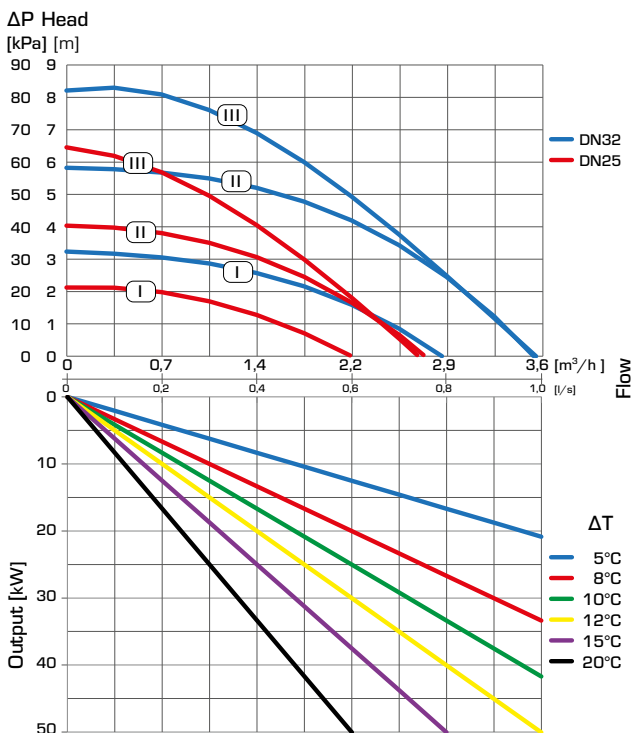

CIRCULATION UNIT

MIXING FUNCTION, SERIES GRxX00

DIMENSIONING, PUMP CAPACITY DIAGRAM

Example: Start with the heat demand of the heating circuit (e.g. 30 kW) and move horizontally to the right in the diagram to the $\Delta t = 10^\circ\text{C}$ (temperature difference between flow and return of the heating circuit). Next go up and find the possible duty points.

Setting I gives duty point A with a residual head of 15 kPa for DN32. Setting II and III gives duty point B with a residual head of 23 kPa for DN32.

SERIES GRA212, GRA232 – Constant differential pressure, Grundfos pump

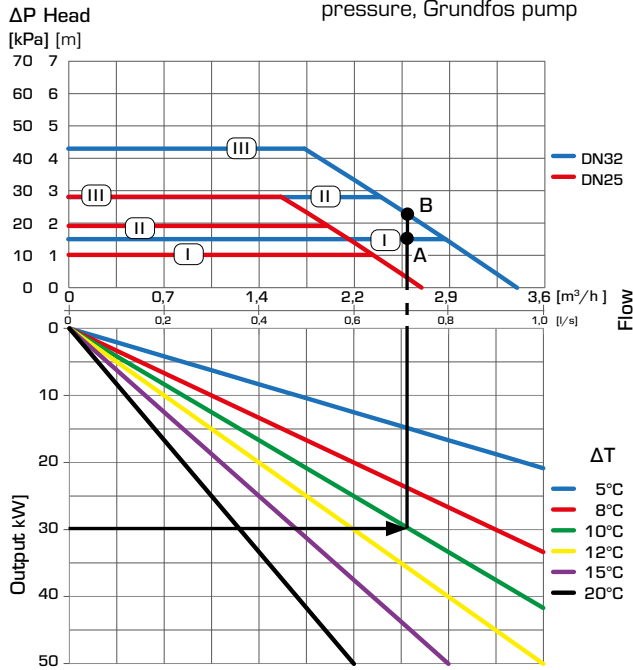

SERIES GRA212, GRA232 – Variable differential pressure, Grundfos pump

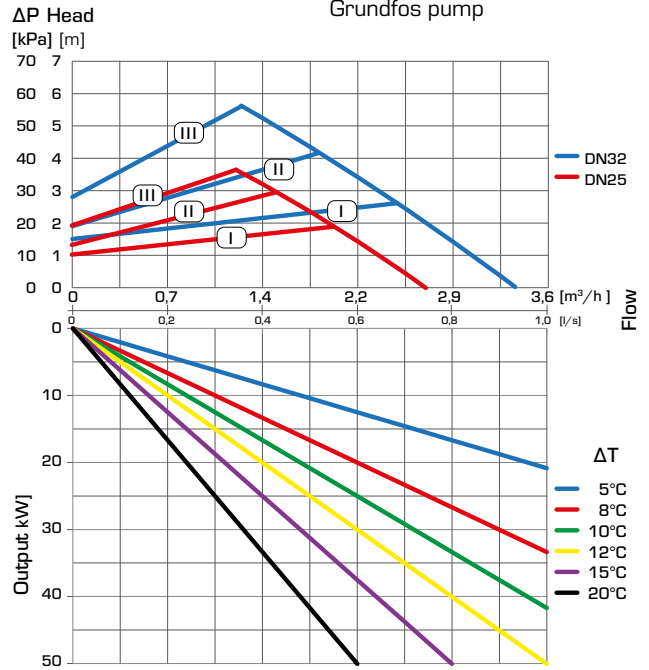

SERIES GRA212, GRA232 – Constant speed, Grundfos pump

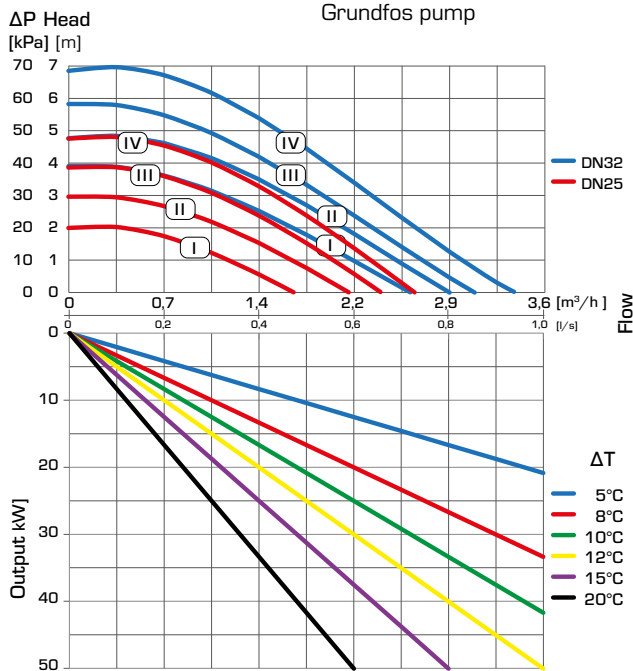

CIRCULATION UNIT

MIXING FUNCTION, SERIES GRxX00

DIMENSIONING, PUMP CAPACITY DIAGRAM

Example: Start with the heat demand of the heating circuit (e.g. 20 kW) and move horizontally to the right in the diagram to the chosen Δt , which is the temperature difference between flow and return of the heating circuit (e.g. 10°C). Next go up and find the possible duty points.

Setting I gives duty point A with a residual head of 18 kPa. Setting II gives duty point B with a residual head of 32 kPa and III gives duty point C with a residual head of 43 kPa.

SERIES GRA311 – Constant differential pressure, Wilo pump

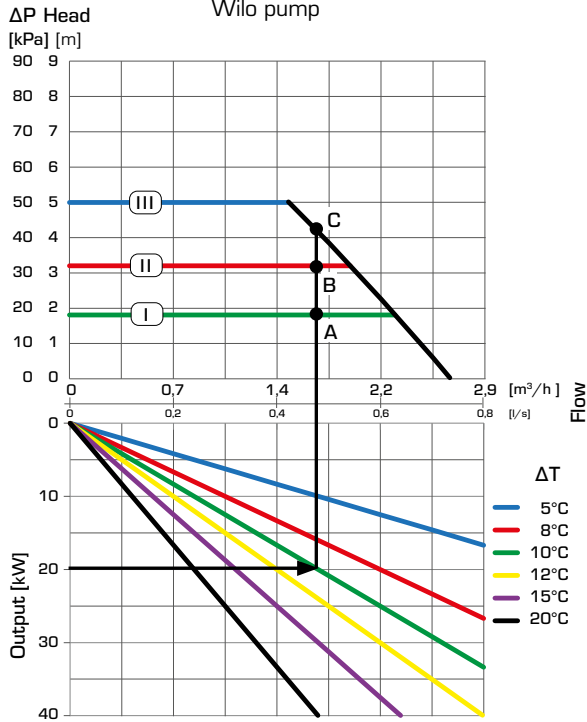

SERIES GRA311 – Variable differential pressure, Wilo pump

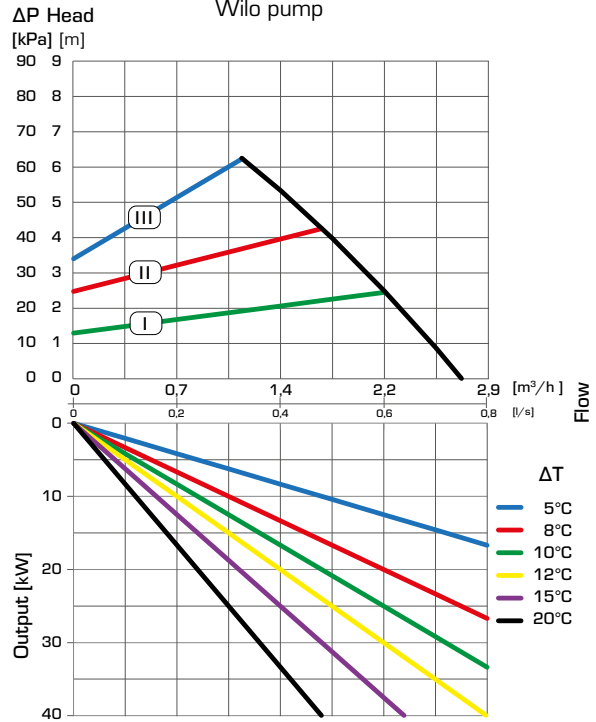

SERIES GRA311 – Ext iPWM 1/ iPWM 2, Wilo pump

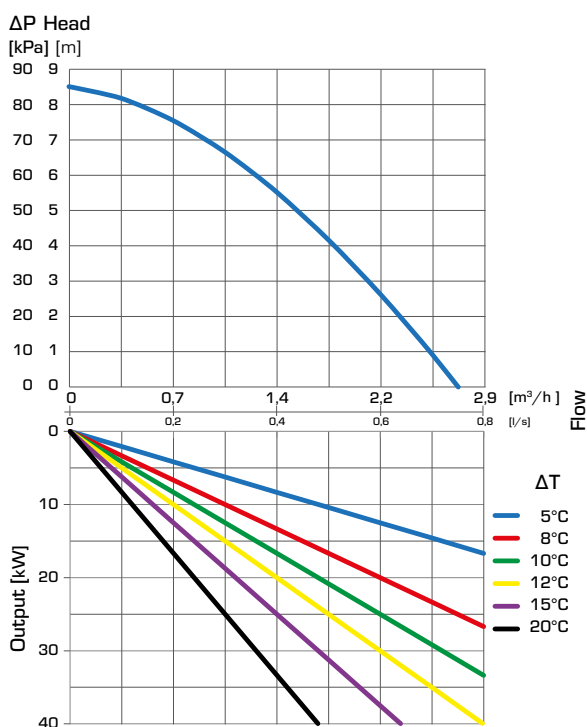

CIRCULATION UNIT

MIXING FUNCTION, SERIES GRxX00

DIMENSIONING, PUMP CAPACITY DIAGRAM

Example: Start with the heat demand of the heating circuit (e.g. 18 kW) and move horizontally to the right in the diagram to the chosen Δt , which is the temperature difference between flow and return of the heating circuit (e.g. 12°C). Next go up and find the possible duty points.

Setting I gives duty point A with a residual head of 20 kPa. Setting II gives duty point B with a residual head of 30 kPa and III gives duty point C with a residual head of 42 kPa.

SERIES GRA394 – Constant differential pressure, Wilo pump

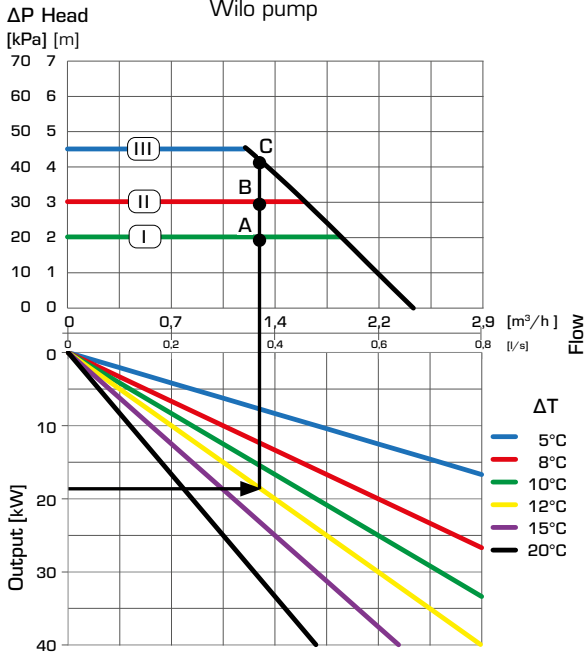

SERIES GRA394 – Variable differential pressure, Wilo pump

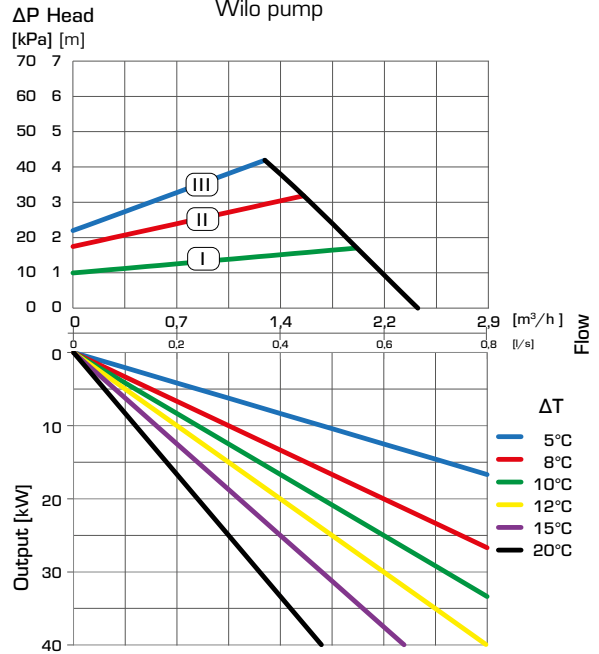

SERIES GRA394 – Constant speed, Wilo pump

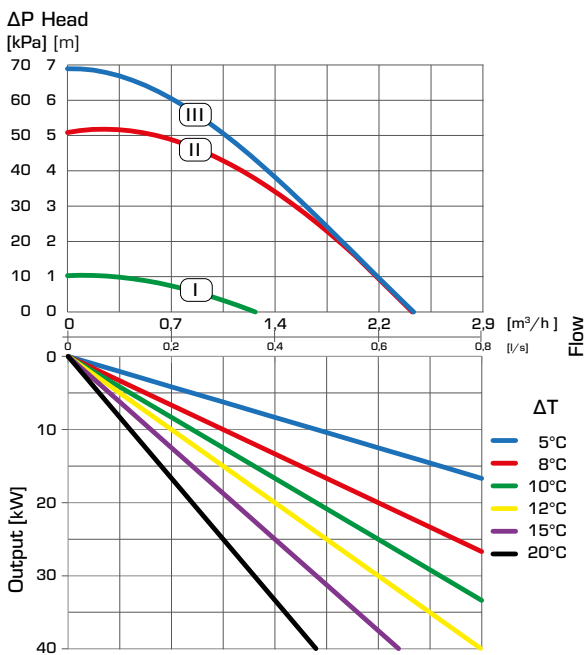

CIRCULATION UNIT

MIXING FUNCTION, SERIES GRxX00

DIMENSIONING, CIRCULATION UNIT CHARACTERISTICS - PRESSURE LOSSES GRF1X1

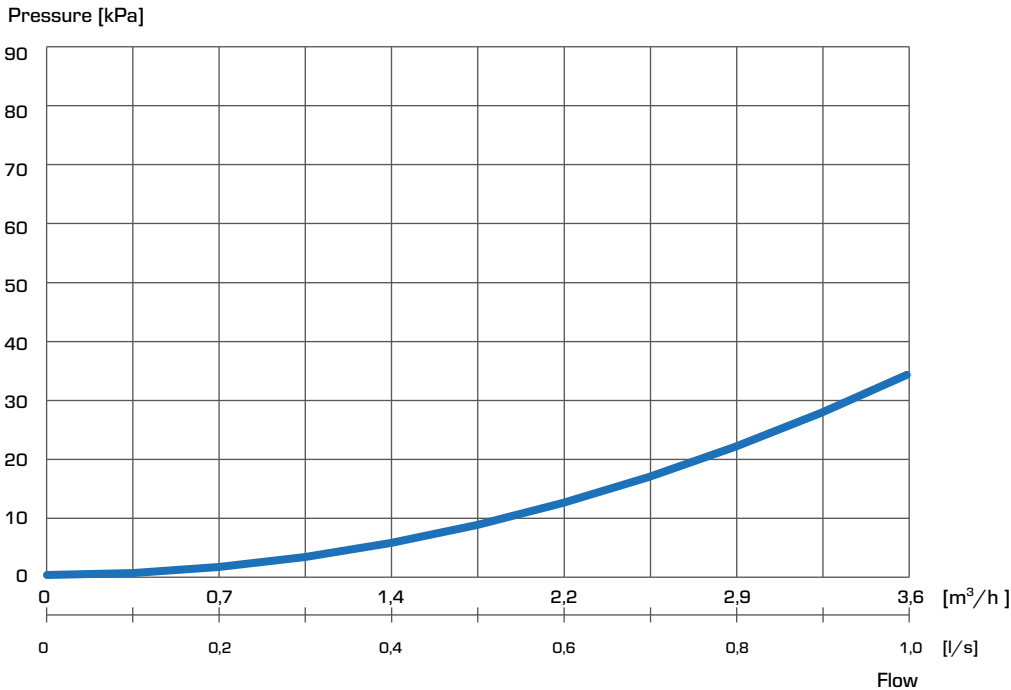

INSTALLATION EXAMPLES

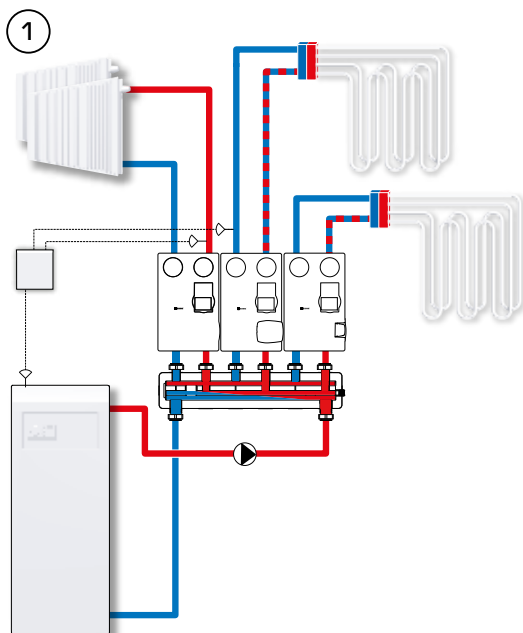

The primary function of the motorized mixing Circulation unit (GRx) is flow temperature control, mixing function. The Series GRx are used in heating systems with controllers. The motorized mixing units need an external controller which will measure the flow temperature and control the actuator according to the system needs. The Circulation units Series GRx are the perfect choice for applications where mixing function is required, and the temperature comfort is set by an external controller.

*The shown applications are only examples of product use!
Before using the product in any application, the regional and national regulations need to be checked.*