

# CIRCULATION UNIT

## MIXING FUNCTION, SERIES GRC200



### PRODUCT DESCRIPTION

The ESBE circulation units Series GRC200 are designed for applications, where precision of mixing and high temperature comfort is required. The mixing groups are equipped with controllers and are used in application where an indoor temperature control via mixing function is desired. An example of such application can be a heat pump serving several zones which are equipped with GRC200 circulation units. The units adjust the heating water temperature to the required temperature for the heating circuit based on the heating curve or measured indoor temperature. For the optimal control and energy management the GRC200 series can control the circuit pump (different working principles are available). The Circulation Mixing Unit ensures the best regulation performances independent from flow rate and low oversizing risk thanks to the progressive valve characteristic, as well as the perfect heating curve characteristic.

The series GRC200 are equipped with a rotary progressive mixing valve, controller series CRx200, two shut-off valves with thermometers, check valve, high class insulation shell and high efficiency circulation pump. The temperature control, mixing function, is performed based on the heating curve and/or measured indoor temperature. The secondary function of the controller CRx200 is pump control which depends on the chosen working principle.

The compact design of the units has been thought through and focus put on components such as pump, valve and controller resulted in high performance of the circulation units.

### VERSIONS

#### Series GRC220

The ESBE series GRC220 are circulation units equipped with a pump, a rotary progressive mixing valve and a weather compensating controller with pump control series CRC217. The series comes in two sizes, DN25 and DN32, with two possible pump choices, Wilo or Grundfos. The pumps can be set to PWM, variable pressure or constant pressure. The Series GRC220 are factory pre-assembled and are ready to be installed in the system.

ESBE recommends enabling pump control in the controller CRC217 for the best performance and energy management (pump control via PWM signal).

The controller series CRC217 can be upgraded to the weather compensated with indoor temperature control version by adding an upgrade kit (see related accessories: CRB913 art. no. 17055500 & CRB916 art. no. 17056400).

#### Series GRC240

The ESBE series GRC240 are circulation units equipped with a pump, a rotary progressive mixing valve and a weather

compensating - indoor temperature controller with pump control series CRD227. The series comes in two sizes, DN25 and DN32, with two possible pump choices, Wilo or Grundfos. The pumps can be set to constant speed, variable pressure, or constant pressure. The Series GRC240 are factory pre-assembled and are ready to be installed in the system.

ESBE recommends enabling pump control in the controller CRD227 for best performance and energy management (pump control via PWM signal).

### Controller Series CRx200

The circulation units are available with two versions of CRx200 controllers. The GRC220 series are equipped with CRC217, a weather compensating controller which can be easily updated to CRD227, a combined weather and indoor temperature controller. The upgrade can be done thanks to the upgrade kit available as accessory: CRB913 art. no. 17055500 & CRB916 art. no. 17056400. The CRD227 controller is a standard equipment of GRC240 series.

The controllers CRC217 and CRD227 includes all features implemented in CRx200 controller platform such as ESBE Smart Software and Self-Adaptive System.

The ESBE Smart Software and Self-Adaptive System are responsible for an advanced heating curve adaptation; in other words, the heating curve will be built and shaped ideal for the specific building, system requirements and weather conditions. Thanks to Smart Software features there is only one setting to be performed and it is the room temperature.

The Controller consist of three main parts: actuator, wireless room unit and outdoor sensor.

- Actuator unit connected to the room display unit by wireless radio connection for easy installation.
- Room display unit which contains the indoor temperature sensor and in which all settings, such as day to day climate adjustments as well as the internal day and weekly program, are set.

&gt;&gt;&gt;

# CIRCULATION UNIT

## MIXING FUNCTION, SERIES GRC200

The controllers CRC217 and CRD227 primary function is indoor climate control. Secondary function is the pump control for optimal system performance and energy management. There are 8 available pump control modes:

- Pump control Off – pump is not controlled by CRx2x7, pump working mode needs to be set on the pump.
- Pump stop – Pump control via valve angle. The pump runs in constant speed until the valve position reach its lower limit. When the valve reach its lower limit, a timer is started. If the valve angle is still in lower limit after the time limit has passed the pump will stop.
- Pump control  $\Delta T$  (difference between supply temperature and return temperature) – two different modes:
  - a) Pump control with regulation to achieve constant  $\Delta T$ .
  - b) Pump control with regulation to achieve a  $\Delta T$  dependent on supply temperature.
- Pump control  $\Delta T$  & pump stop – combined function of pump stop and  $\Delta T$  control. Meaning that,  $\Delta T$  regulation of pump speed when the water regulation is fulfilled plus pump is stopped if the valve angle is lower than the minimum angle.
- Pump control  $\Delta T$  & flow limit – pump will be controlled according to the  $\Delta T$ . However if the set flow limit is reached the controller will not allow the pump to work with higher speed.
- Pump control  $\Delta T$  & flow limit & pump stop – pump will be controlled according to the  $\Delta T$ . However, if the set flow limit is reached the controller will not allow the pump to work with higher speed, and when the valve reach lower limit the pump will be turned off after a time limit.
- Flow control – Pump regulation independent of temperature. The pump will regulate to achieve the set flow.
- Flow control & pump stop – Pump regulation independent of temperature. The pump will regulate to achieve the set flow. However, when the valve reach the lower limit the pump will be turned off after a time limit.

### SERVICE AND MAINTENANCE

The circulation unit does not require any specific maintenance under normal conditions.

### KEY BENEFITS

- Highly efficient circulation pumps
- High class insulation of hydraulic parts
- Progressive valve characteristic
- Quick-FIT interface between controller and valve
- Weather compensated controller (GRC220)
- Combined weather and indoor temperature controller (GRC240)
- Pump control via PWM signal with 8 different working modes
- Possible controller upgrade
- ESBE Smart Software & Self-Adaptive System
- Compact design
- Tested, pre-assembled and ready to use
- Designed to last and perform
- High-end product finish

### RELATED ACCESSORIES

See separate data sheet for further detailed information.

#### ESBE Manifold

Manifold for 1, 2, or 3 circulation units. With integrated separator function.

Art. No.		
66001100	_____	GMA411 - for 1 unit
66001600	_____	GMA521 - for 2 units
66001700	_____	GMA531 - for 3 units

Manifold for 2, 3, 4 or 5 circulation units. Without integrated separator function.

Art. No.		
66001200	_____	GMA421 - for 2 units
66001300	_____	GMA431 - for 3 units
66001400	_____	GMA441 - for 4 units
66001500	_____	GMA451 - for 5 units

#### OPTIONAL EQUIPMENT - UPGRADE KIT FOR CONTROLLERS

Art. No.		
17055500	_____	CRB913 Room unit, wireless
17056400	_____	CRB916 Communication radio module, wireless

#### OPTIONAL EQUIPMENT

Art. No.		
17056200	_____	CRA915 UK Plug

#### SPARE PARTS

Art. No.		
67007000	___	GSP963 Controller CRC217 QF W (GRC221)
67007100	___	GSP963 Controller CRC217 QF G (GRC222)
67007200	___	GSP964 Controller CRD227 QF W (GRC241)
67007300	___	GSP964 Controller CRD227 QF G (GRC242)
67005700	_____	GSP932 Pump Wilo STG 25/8 (GRC221, GRC241)
67000500	_____	GSP907 Pump Grundfos UPM3 25-70 (GRC222, GRC242)

# CIRCULATION UNIT

## MIXING FUNCTION, SERIES GRC200

### PRODUCT ASSORTMENT

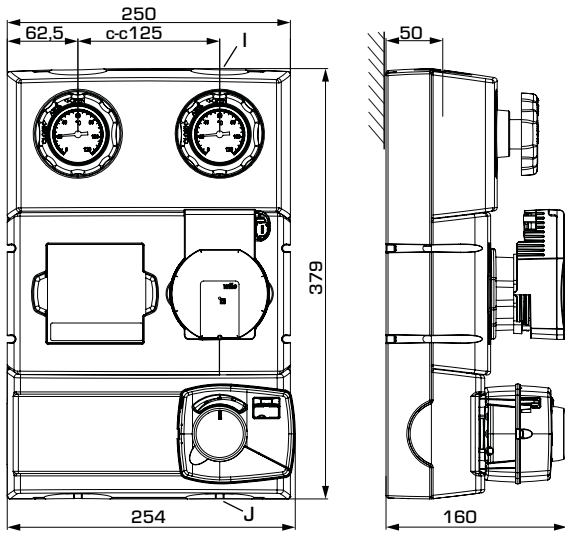

GRC221/GRC241

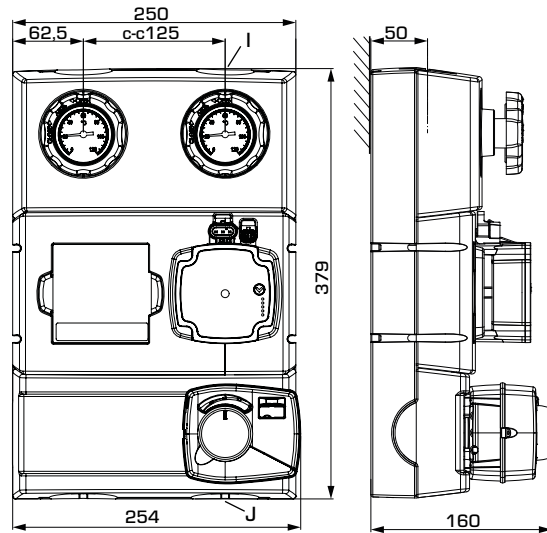

GRC222/GRC242

### SERIES GRC220

Art. No.	Reference	DN	Pump	Controller	Connections		Weight [kg]	Replaces	Note
					I	J			
61044100	GRC221	25	Wilo PARA STG 25/130/8-60/0	GRC217	G 1"	G 1½"	6,1	61040200	
61044200		32			G 1¼"	G 1½"	6,3	61040700	
61044300	GRC222	25	Grundfos UPM3 Hybride 25-70 130		G 1"	G 1½"	6,0	61040900	
61044400		32			G 1¼"	G 1½"	6,3	61041100	

### SERIES GRC240

Art. No.	Reference	DN	Pump	Controller	Connections		Weight [kg]	Replaces	Note
					I	J			
61044500	GRC241	25	Wilo PARA STG 25/130/8-60/0	CRD227	G 1"	G 1½"	6,3	61041300	With Room display unit
61044600		32			G 1¼"	G 1½"	6,7	61041400	
61044700	GRC242	25	Grundfos UPM3 Hybride 25-70 130		G 1"	G 1½"	6,2	61041500	
61044800		32			G 1¼"	G 1½"	6,4	61041600	

# CIRCULATION UNIT

## MIXING FUNCTION, SERIES GRC200

**TECHNICAL DATA**

 Visit [esbe.eu](http://esbe.eu) for further detailed information.

**The Circulation unit, in general**

Pressure class: \_\_\_\_\_ PN 10  
 Working pressure: \_\_\_\_\_ 1,0 MPa (10 bar)  
 Connections, \_\_\_\_\_ Internal thread (G), ISO 228/1  
 \_\_\_\_\_ External thread (G), ISO 228/1  
 Insulation: \_\_\_\_\_ EPP λ 0,036 W/mK

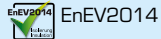

Media: \_\_\_\_\_ Heating water (in accordance with VDI2035)  
 \_\_\_\_\_ Water / Glycol mixtures, max. 50%.  
 (water / glycol mixtures are affecting the pump performance. In case of Applications where water / glycol mixtures are used, pump performance should be considered.)

**Series GRC221**

Media temperature: \_\_\_\_\_ max. +100°C  
 \_\_\_\_\_ min. +5°C  
 Ambient temperature: \_\_\_\_\_ max. +55°C  
 \_\_\_\_\_ min. 0°C  
 Pump type: \_\_\_\_\_ Wilo PARA STG 25-130/8-60/0  
 Power supply: \_\_\_\_\_ 230 ± 10% V AC, 50/60 Hz  
 Power consumption: \_\_\_\_\_ 10-75 W  
 Enclosure rating: \_\_\_\_\_ IP X4D  
 Insulation class: \_\_\_\_\_ F  
 EEI (Energy Efficiency Index): \_\_\_\_\_ <0,21  
 Valve type: \_\_\_\_\_ Mixing valve VRG432  
 Max. differential pressure drop: \_\_\_\_\_ 100kPa (1bar)  
 Close off pressure: \_\_\_\_\_ 200 kPa (2 bar)  
 Leakrate in % of flow\*: \_\_\_\_\_ < 0,05%  
 \* Differential pressure 100kPa (1 bar)

Controller type: \_\_\_\_\_ CRC217  
 Power supply: \_\_\_\_\_ 230 ± 10% V AC, 50 Hz  
 Power consumption: \_\_\_\_\_ 10 VA  
 Running time at max. speed: \_\_\_\_\_ 30s  
 Enclosure rating: \_\_\_\_\_ IP41  
 Protection class: \_\_\_\_\_ II  
 ErP Temperature control class: \_\_\_\_\_ III  
 Energy efficiency contribution: \_\_\_\_\_ 1,5%

**Material, in contact with water**

Components: \_\_\_\_\_ Brass, Cast iron, Steel  
 Sealing material: \_\_\_\_\_ PTFE, Aramid fibre, EPDM

**Conformities and certificates**

 LVD 2014/35/EU  
 EMC 2014/30/EU  
 RoHS3 2015/863/EU  
 ErP 2009/125/EU  
 PED 2014/68/EU, article 4.3

**Series GRC222**

Media temperature: \_\_\_\_\_ max. +110°C  
 \_\_\_\_\_ min. +5°C  
 Ambient temperature: \_\_\_\_\_ max. +55°C  
 \_\_\_\_\_ min. 0°C  
 Pump type: \_\_\_\_\_ Grundfos UPM3 Hybride 25-70 130  
 Power supply: \_\_\_\_\_ 230 ± 10% V AC, 50/60 Hz  
 Power consumption: \_\_\_\_\_ 2-52 W  
 Enclosure rating: \_\_\_\_\_ IP 44  
 Insulation class: \_\_\_\_\_ N/A  
 EEI (Energy Efficiency Index): \_\_\_\_\_ <0,20  
 Valve type: \_\_\_\_\_ Mixing valve VRG432  
 Max. differential pressure drop: \_\_\_\_\_ 100kPa (1bar)  
 Close off pressure: \_\_\_\_\_ 200 kPa (2 bar)  
 Leakrate in % of flow\*: \_\_\_\_\_ < 0,05%  
 \* Differential pressure 100kPa (1 bar)

Controller type: \_\_\_\_\_ CRC217  
 Power supply: \_\_\_\_\_ 230 ± 10% V AC, 50 Hz  
 Power consumption: \_\_\_\_\_ 10 VA  
 Running time at max. speed: \_\_\_\_\_ 30s  
 Enclosure rating: \_\_\_\_\_ IP41  
 Protection class: \_\_\_\_\_ II  
 ErP Temperature control class: \_\_\_\_\_ III  
 Energy efficiency contribution: \_\_\_\_\_ 1,5%

**Material, in contact with water**

Components: \_\_\_\_\_ Brass, Cast iron, Steel  
 Sealing material: \_\_\_\_\_ PTFE, Aramid fibre, EPDM

**Conformities and certificates:**

 LVD 2014/35/EU  
 EMC 2014/30/EU  
 RoHS3 2015/863/EU  
 ErP 2009/125/EU  
 PED 2014/68/EU, article 4.3

**WIRING**

Please see the Installation Instruction

# CIRCULATION UNIT

## MIXING FUNCTION, SERIES GRC200

### TECHNICAL DATA

 Visit [esbe.eu](http://esbe.eu) for further detailed information.

#### Series GRC241

Media temperature: \_\_\_\_\_ max. +100°C  
 \_\_\_\_\_ min. +5°C  
 Ambient temperature: \_\_\_\_\_ max. +55°C  
 \_\_\_\_\_ min. 0°C  
 Pump type: \_\_\_\_\_ Wilo PARA STG 25-130/8-60/0  
 Power supply: \_\_\_\_\_ 230 ± 10% V AC, 50/60 Hz  
 Power consumption: \_\_\_\_\_ 10-75 W  
 Enclosure rating: \_\_\_\_\_ IP X4D  
 Insulation class: \_\_\_\_\_ F  
 EEI (Energy Efficiency Index): \_\_\_\_\_ <0,21  
 Valve type: \_\_\_\_\_ Mixing valve VRG432  
 Max. differential pressure drop: \_\_\_\_\_ 100kPa (1 bar)  
 Close off pressure: \_\_\_\_\_ 200 kPa (2 bar)  
 Leakrate in % of flow\*: \_\_\_\_\_ < 0,05%  
 \* Differential pressure 100kPa (1 bar)

Controller type: \_\_\_\_\_ CRD227  
 Power supply - Actuator unit: \_\_\_\_\_ 230 ± 10% V AC, 50 Hz  
 Room display unit, wireless: \_\_\_\_\_ 2x 1,5 V LR6/AA  
 Power consumption: \_\_\_\_\_ 10 VA  
 Running time at max. speed: \_\_\_\_\_ 30s  
 Battery endurance, wireless room display unit: \_\_\_\_\_ 1 year  
 Enclosure rating - Actuator unit: \_\_\_\_\_ IP41  
 Room display unit, wireless: \_\_\_\_\_ IP20  
 Protection class: \_\_\_\_\_ II  
 ErP Temperature control class: \_\_\_\_\_ VII  
 Energy efficiency contribution: \_\_\_\_\_ 3,5%  
 Radio frequency (wireless room unit): \_\_\_\_\_ 868 MHz  
 ITU region 1 approved acc. to EN 300220-2

#### Material, in contact with water

Components of: \_\_\_\_\_ Brass, Cast iron, Steel  
 Sealing material of: \_\_\_\_\_ PTFE, Aramid fibre, EPDM

#### Conformities and certificates

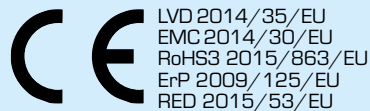

PED 2014/68/EU, article 4.3

#### Series GRC242

Media temperature: \_\_\_\_\_ max. +110°C  
 \_\_\_\_\_ min. +5°C  
 Ambient temperature: \_\_\_\_\_ max. +55°C  
 \_\_\_\_\_ min. 0°C  
 Pump type: \_\_\_\_\_ Grundfos UPM3 Hybride 25-70 130  
 Power supply: \_\_\_\_\_ 230 ± 10% V AC, 50/60 Hz  
 Power consumption: \_\_\_\_\_ 2-52 W  
 Enclosure rating: \_\_\_\_\_ IP 44  
 Insulation class: \_\_\_\_\_ N/A  
 EEI (Energy Efficiency Index): \_\_\_\_\_ <0,20  
 Valve type: \_\_\_\_\_ Mixing valve VRG432  
 Max. differential pressure drop: \_\_\_\_\_ 100kPa (1 bar)  
 Close off pressure: \_\_\_\_\_ 200 kPa (2 bar)  
 Leakrate in % of flow\*: \_\_\_\_\_ < 0,05%  
 \* Differential pressure 100kPa (1 bar)

Controller type: \_\_\_\_\_ CRD227  
 Power supply - Actuator unit: \_\_\_\_\_ 230 ± 10% V AC, 50 Hz  
 - Room display unit, wireless: \_\_\_\_\_ 2x 1,5 V LR6/AA  
 Power consumption: \_\_\_\_\_ 10 VA  
 Running time at max. speed: \_\_\_\_\_ 30s  
 Battery endurance, wireless room display unit: \_\_\_\_\_ 1 year  
 Enclosure rating - Actuator unit: \_\_\_\_\_ IP41  
 - Room display unit, wireless: \_\_\_\_\_ IP20  
 Protection class: \_\_\_\_\_ II  
 ErP Temperature control class: \_\_\_\_\_ VII  
 Energy efficiency contribution: \_\_\_\_\_ 3,5%  
 Radio frequency (wireless room unit): \_\_\_\_\_ 868 MHz  
 ITU region 1 approved acc. to EN 300220-2

#### Material, in contact with water

Components: \_\_\_\_\_ Brass, Cast iron, Steel  
 Sealing material: \_\_\_\_\_ PTFE, Aramid fibre, EPDM

#### Conformities and certificates

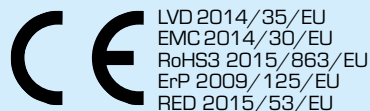

PED 2014/68/EU, article 4.3

### WIRING

Please see the Installation Instruction

# CIRCULATION UNIT

## MIXING FUNCTION, SERIES GRC200

**TECHNICAL DATA**

 Visit [esbe.eu](http://esbe.eu) for further detailed information.

**VALVE CHARACTERISTICS**

Flow [%]

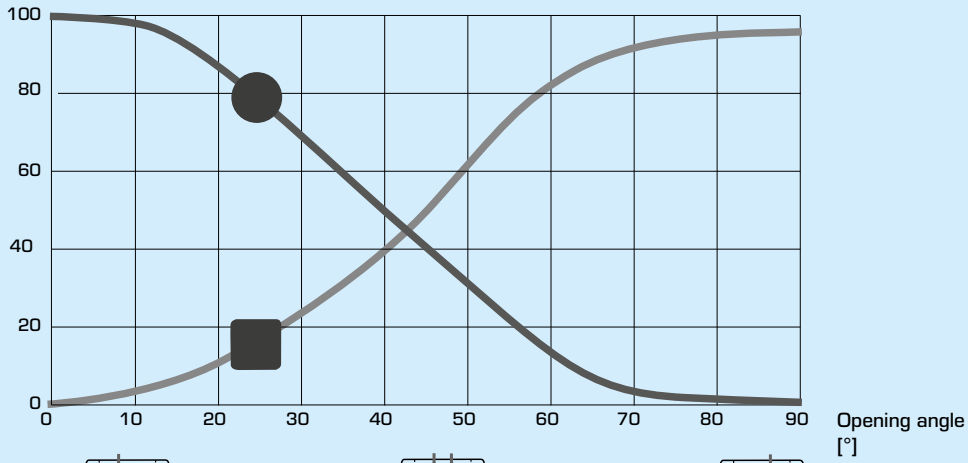

Opening angle [°]

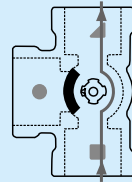
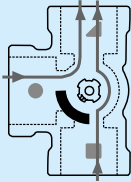
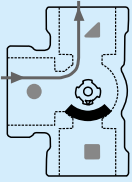

# CIRCULATION UNIT MIXING FUNCTION, SERIES GRC200

## DIMENSIONING, PUMP CAPACITY DIAGRAM

**Example:** Start with the heat demand of the heating circuit (e.g. 25 kW) and move horizontally to the right in the diagram to the  $\Delta T = 12^\circ\text{C}$  (temperature

difference between flow and return of the heating circuit). Next go up and find the working point and read the available pressure of the pump on the left.

### SERIES GRC2x1 - Constant differential pressure, Wilo pump

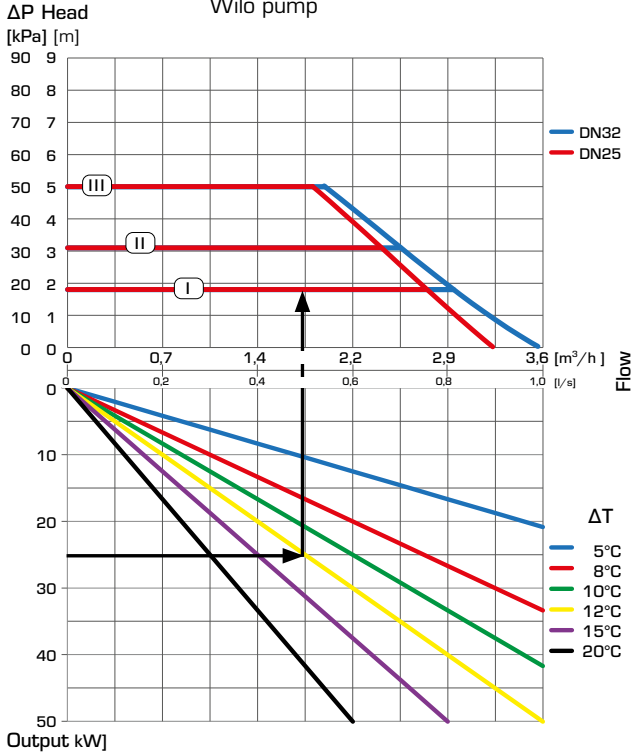

### SERIES GRC2x1 - Variable differential pressure, Wilo pump

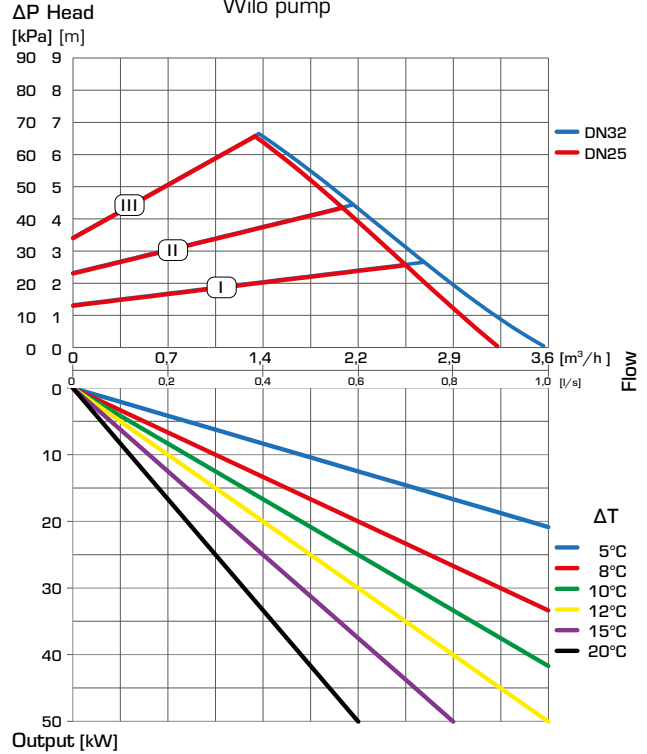

### SERIES GRC2x1 - PWM, Wilo pump

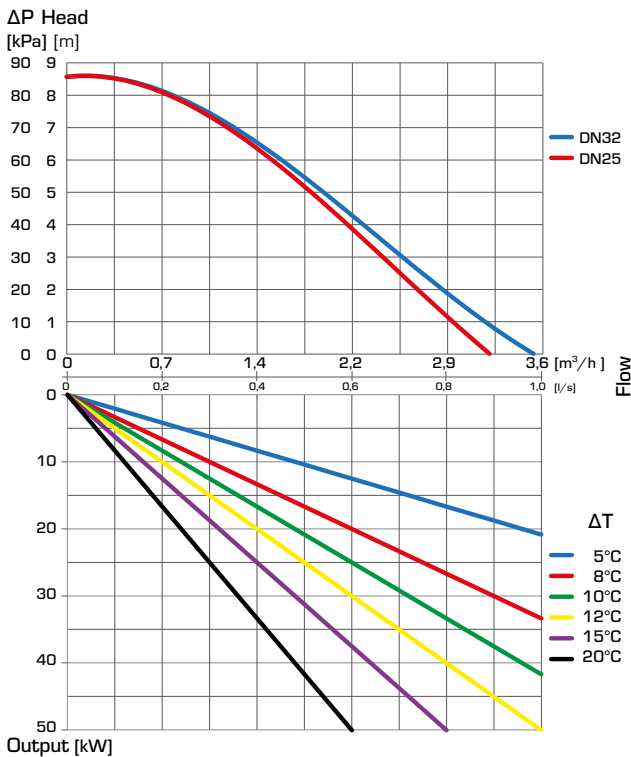

# CIRCULATION UNIT

## MIXING FUNCTION, SERIES GRC200

### DIMENSIONING, PUMP CAPACITY DIAGRAM

**Example:** Start with the heat demand of the heating circuit (e.g. 25 kW) and move horizontally to the right in the diagram to the  $\Delta T = 10^{\circ}\text{C}$  (temperature

difference between flow and return of the heating circuit). Next go up and find the working point and read the available pressure of the pump on the left.

#### SERIES GRC2x2 - Constant differential pressure, Grundfos pump

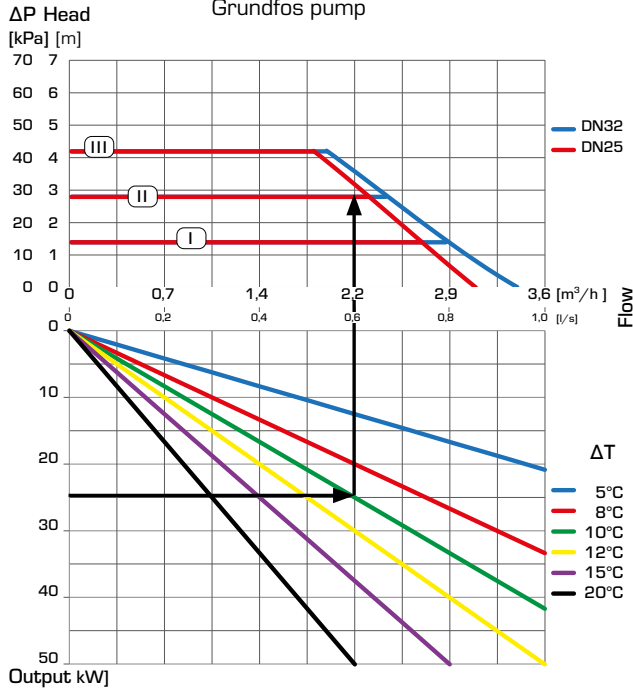

#### SERIES GRC2x2 - Variable differential pressure, Grundfos pump

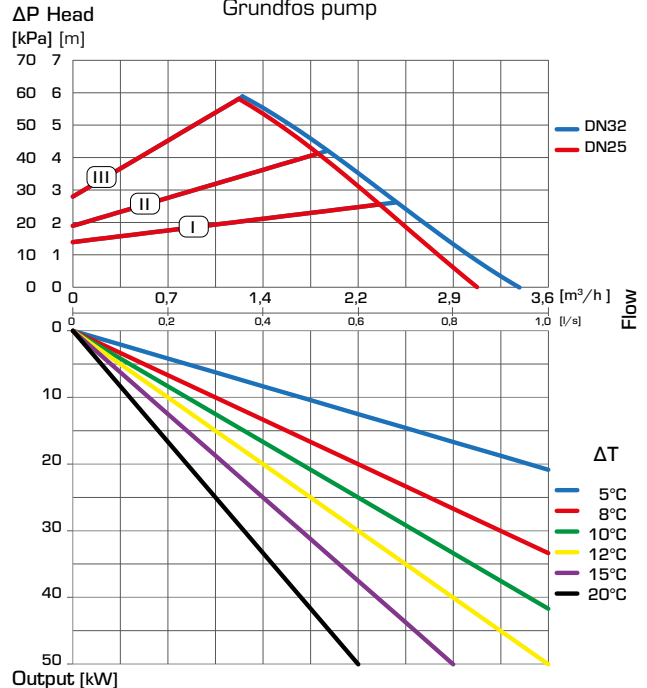

#### SERIES GRC2x2 - PWM, Grundfos pump

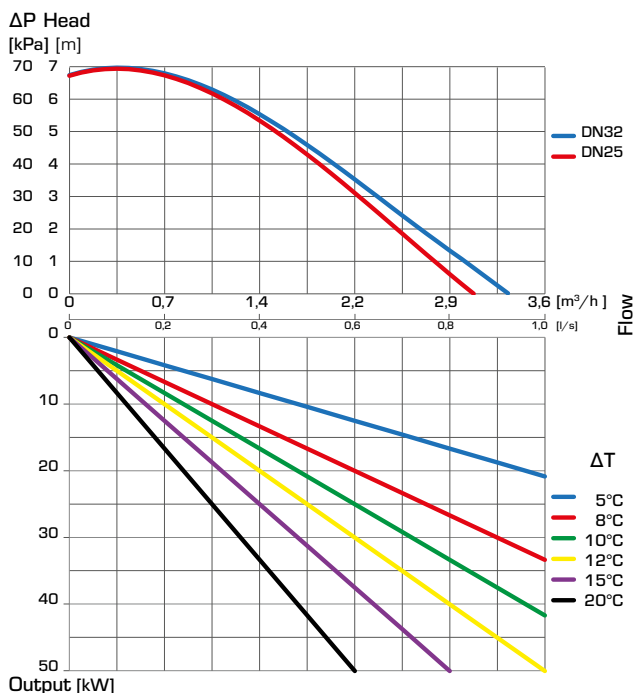

# CIRCULATION UNIT

## MIXING FUNCTION, SERIES GRC200

### INSTALLATION EXAMPLE

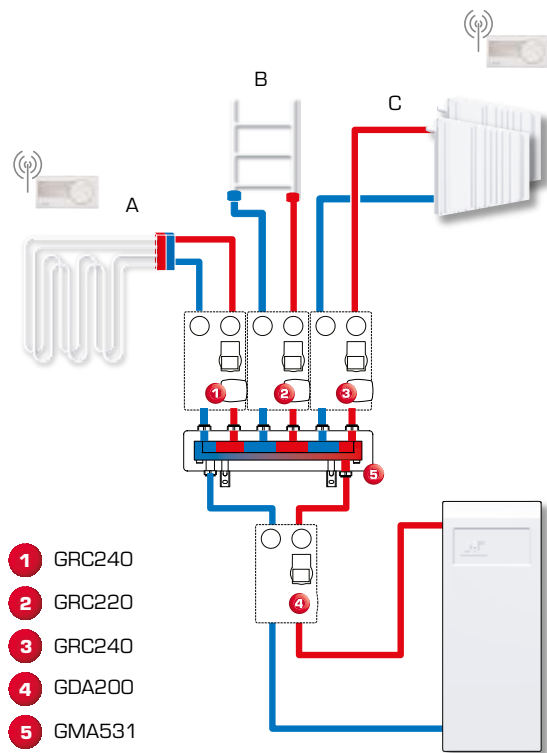

#### The circulation unit series GRC200 in a heating system with a heat pump.

The heating circuits A & C are equipped with GRC240 and the heating circuit B is equipped with GRC220.

The GRC240 units are controlling the heating circuits according to the heating curve and the indoor temperature, as well as controlling the pump according to  $\Delta T$  with pump on/off function.

The GRC220 unit is controlling the heating circuit according to the heating curve and controlling the pump according to  $\Delta T$  with pump on/off function.

The benefits of using the circulation units series GRC200 in this application are:

- High indoor temperature comfort thanks to ESBE Smart Control and Self-Adaptive System
- Controlling the  $\Delta T$ , return temperature to the heat pump to maximize the COP (Coefficient of Performance) and system performance
- Controlling the pump on/off for energy savings in case when heat is not required.

*The shown applications are only examples of product use!  
Before using the product in any application, the regional and national regulations need to be checked.*